

new X0 SMART WASP



X0ms | X0ms-MT | X0ps | X0ps-MT **X0 Series**



Smart Manufacturing & Packaging Solutions
www.pallet-stretch-wrapping-machines.com.au
 Phone 1300 722 868

Model	X0ms	X0ms-MT	X0ps	X0ps-MT
Essential Parameter	Mechanical Stretch Mechanical	Mechanical Stretch+M turntable	Pre-stretch	Pre-stretch+M Turntable
Machine size (mm)	2435*1650*2424	2797*1722*2419	2435*1650*2424	2797*1722*2419
Machine weight	530KG	530KG	550KG	550KG
Machine power	1.2KW	1.2KW	1.5KW	1.5KW
Voltage	220V			
Load weight	1500KG	800KG	1500KG	800KG
Turntable speed	0-12rpm			
Packing speed	30 loads/h			
Column height	2400mm Standard (2800mm, 3200mm and 3600mm optional, not stocked made to order)			
Packing height	2000mm Standard (2400mm, 2800mm 32mm optional, not stocked, made to order)			
Turntable height	81mm			
Turntable size	1650mm Standard (1800mm / 2000mm / 2200mm / 2400mm optional, not stocked, made to order)			
Up&down speed	0-5.9m/min			
Pre-stretch rate	—	—	250%	250%
Film Width	500mm			
Film paper Core	76mm			
Fix film on pallet	Manual			
Certificate	CE			
Appearance/Craft	Steel, Aluminum			
Machine materials	Steel, Aluminum			
Industrial appearance	Metal plate			
Indicator light	Three Color LED - BLUE ready to run, GREEN running a cycle, RED fault detected			
Control	PCB Integrated Circuit Plate			
Soft start & stop	●	●	●	●
Intelligent Alarm	●	●	●	●
Stop at original	●	●	●	●
Turntable lock	—	●	—	●
PLC	PCB Integrated Circuit Plate			
Inverter	PCB Integrated Circuit Plate			
Sensor switch	SICK			
Touch screen	SMART WASP			
Motor	SMART WASP			
Safety device	Pressure sensitive safety stop to avoid crushing incidents - Safety brake makes it impossible for the wrapping head to drop			
Optional Functions	Pressure sensitive safety stop to avoid crushing incidents - Safety brake makes it impossible for the wrapping head to drop			
Top Pressure Function	○	○	○	○
Ramp	○	○	○	○
Weighing	○	○	○	○

Annotation: ● With the configuration ○ Optional configuration — No configuration

*The parameter information is for reference only

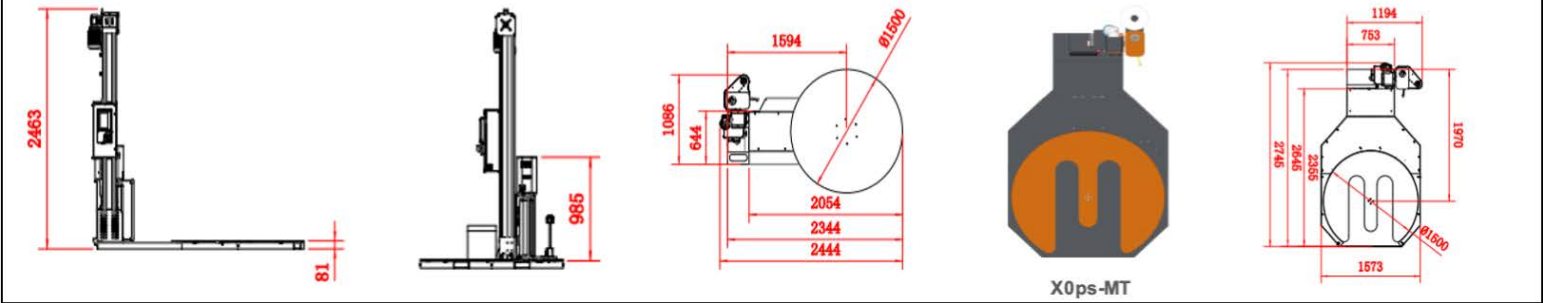

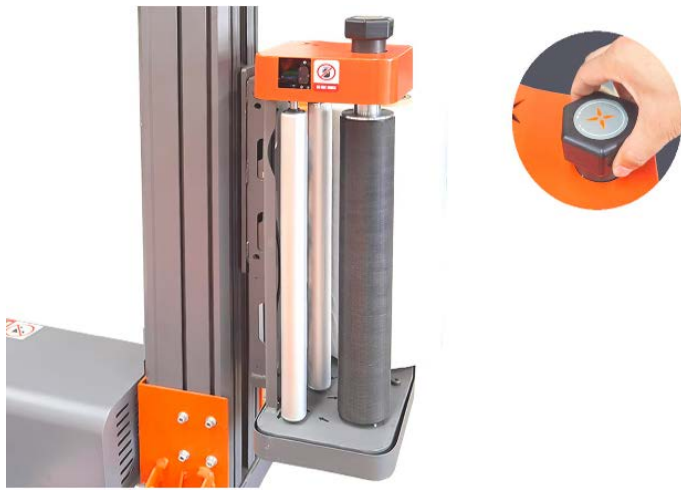

X0ms with new generation of mechanical resistance film carriage

1. Adjustable knob with physical feedback for the wrapping tension, is easy and convenient to adjust

X0ps with the latest cost-saving power pre-stretching film carriage

1. Use the touch screen to precisely adjust the wrapping tension
2. The maximum pre-stretching ratio is 250%, giving you impressive film saving



PCB control system

1. Four independent chips provide the smarts to control the operation of the wrapper
2. The integrated circuit system, reduces maintenance and repair cost.



Intuitive and Easy to Operate Touch Screen 6 Memory Functions + One Button Start

1. Easy to operate clear bright touch screen that your operators will love
2. Six program memory function, make parameter setting easier with simple recall
3. Two levels of Password protection to stop those that like to play with setting
4. One button to start the wrapping cycle ensures convenient simple operation



All-in-one alloy Aluminum Column with Lifetime Warranty

1. 4000 tons extruded column, integrally formed, solid and durable
2. Modular assembly, easy to install
3. Double chain lifting system, ensures safety
4. LED tri-color indicator light

3 YEAR FACTORY BACKED WARRANTY

